

## User's Guide



### ***HDSDI-ACR 100*** ***SDI-AVR 100***

**High Definition SDI to Component Video/RGB Converter**  
**SDI to Video/RGB Converter**

## Overview

The Extron HDSDI-ACR 100 converts a high definition (HD) serial digital interface (SDI) input (SMPTE-292M) to either analog component or RGB video. The converter supports the 720p, 1080i, and 1080p HDTV rates. The 1080p rate is limited to a maximum 30 Hz refresh rate and includes 1080p segmented frame 23.94/24. DIP switches select between RGB and component video, and, for component video output, between bi-level and tri-level sync, and sync on the Y output or on all outputs.

The Extron SDI-AVR 100 converts an SDI (4:2:2) video input at the 270 Mbs rate to analog video. When an SDI input is applied, the converter produces simultaneous composite and S-video outputs, and either component (Y, R-Y, and B-Y) or RGB video. A DIP switch selects between a component or RGB video output. The SDI-AVR 100 accepts NTSC, PAL, and Betacam (Beta 50/60), autodetects the format, and deserializes the input. The converter can output NTSC or PAL color bars, which are DIP switch selectable.

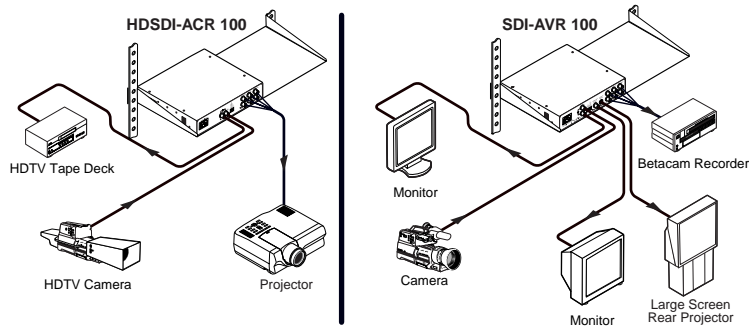

**Figure 1 — Typical HDSDI-ACR 100 and SDI-AVR 100 applications**

The input signal is equalized for distances of 330 feet (100 meters) (HDSDI-ACR 100) or 1000 feet (305 meters) (SDI-AVR 100) on high quality cable such as Extron SHR cable. A relocked loop-through allows the HDSDI/SDI input to be sent to other equipment.

The user must select between an RGB or component video output using a DIP switch. The converters output separate H and V sync signals and composite sync simultaneously. Selecting the sync-on-green output requires changing a DIP switch position.

The converters have internal switching power supplies.

## Installation

1. For optional rack mounting, mount the converter on one side of a 19" 1U Universal Rack Shelf (Extron part #60-190-01) (figure 2).
  - a. If feet were previously installed on the bottom of the case, remove them.

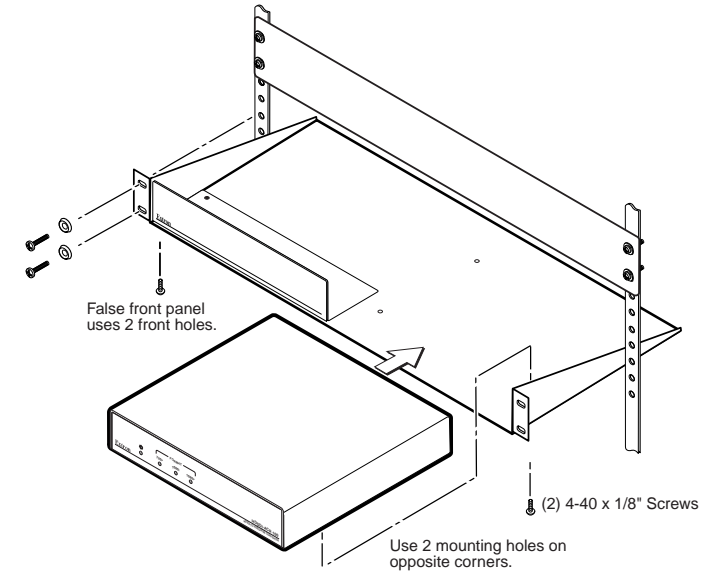
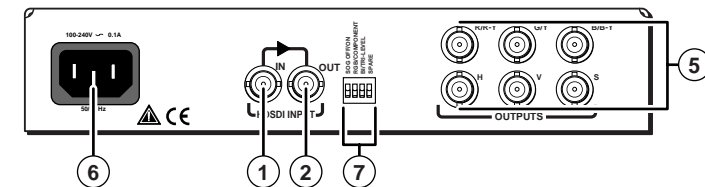

**Figure 2 — Rack mounting the SDI-AVR 100**

- b. Mount the SDI-AVR 100 on the rack shelf, using two 4-40 x 1/8 screws in opposite (diagonal) corners.
2. If desired, attach a false front panel or a second 1/2-rack-width device to the other side of the shelf.
3. Attach the rack shelf to the rack using four 10-32 x 3/4" bolts and four #10 beveled dress washers.

## Rear Panel Cabling

Figure 3 shows the HDSDI-ACR 100 connections and DIP switches. Figure 4 shows the SDI-AVR 100.



**Figure 3 — HDSDI-ACR 100 rear panel**

- ① **Input In connector** — Connect an HDSDI (HDSDI-ACR 100) or SDI (SDI-AVR 100) input to this BNC connector.
- ② **Input Out connector** — Connect an HDSDI (HDSDI-ACR 100) or SDI (SDI-AVR 100) device to this BNC connector. The converter outputs a relocked SDI or HDSDI loop-through on this BNC.

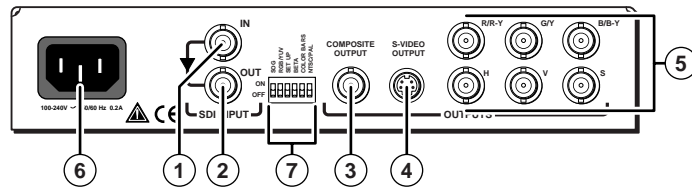
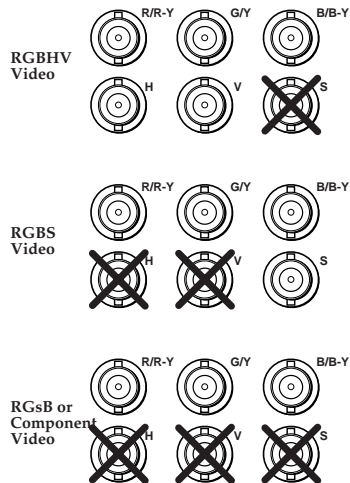

Figure 4 — SDI-AVR 100 rear panel

- ③ **Composite Output connector (SDI-AVR 100 only)** — Connect a composite video display device to this BNC connector. This output is available whenever an active SDI signal is applied to the SDI input connector, ①.
- ④ **S-video Output connector (SDI-AVR 100 only)** — Connect an S-video device to this 4-pin mini DIN connector. This output is available whenever an active SDI signal is applied to the SDI input connector, ①.
- ⑤ **RGB/component video output connectors**

**NOTE** Ensure that the rear panel DIP switches are in the correct configuration (see Rear Panel Controls).



**RGBHV video connection** — Connect to five BNC connectors as shown.

**RGBS video connection** — Connect to four BNC connectors as shown.

**RGsB and component video connection** — Connect to three BNC connectors as shown.

- ⑥ **AC power connector** — Plug a standard IEC power cord into this connector to connect the converter to a 100 to 240VAC, 50 Hz or 60 Hz power source.

**Rear Panel Controls**

- ⑦ **DIP switches**

**SOG switch** — Set this switch to the On position to output sync-on-green for RGB video (RGsB). Set the switch off for RGBHV or RGBS video.

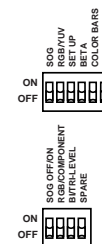

**RGB/Component (HDSDI-ACR 100) or RGB/YUV (SDI-AVR 100) switch** — Set this switch to the Off position to output RGB video. Set the switch on for component video.

**Bi/tri-level switch (HDSDI-ACR 100 only)** — Set this switch to the On position to output tri-level sync on the component video output. Set the switch off for bi-level sync.

**HDSDI-ACR 100 switch configuration**

| Output video format           | SOG    | RGB/Component | Bi/tri-level |
|-------------------------------|--------|---------------|--------------|
| RGBHV/RGBS                    | Off    | Off           | Either       |
| RGsB                          | On     | Off           | Either       |
| Y, R-Y, B-Y w/ bi-level on Y  | Either | On            | Off          |
| Y, R-Y, B-Y w/ tri-level on Y | Either | On            | On           |

**SDI-AVR 100 switch configuration**

| Output video format | SOG    | RGB/YUV |
|---------------------|--------|---------|
| RGBHV/RGBS          | Off    | Off     |
| RGsB                | On     | Off     |
| Y, R-Y, B-Y         | Either | On      |

**Set Up switch (SDI-AVR 100 only)** — Set this switch to the On position to output an NTSC signal that is on the 7.5 IRE pedestal. Set the switch off to return the signal to the normal level.

**Beta switch (SDI-AVR 100 only)** — Set this switch to the On position to set the color level of the YUV output to the Betacam level. Set the switch off to restore the YUV output to the normal level. If a Betacam signal is input, the switch should be set to On to output the Betacam format. Otherwise, the output will be NTSC or PAL.

**Color Bars switch (SDI-AVR 100 only)** — Set this switch to the On position to output NTSC or PAL color bars. Set the switch off for the converted video input.

**NTSC/PAL switch (SDI-AVR 100 only)** — Used in conjunction with the Color Bars switch only, set this switch to the On position to output PAL color bars. Set the switch off for NTSC color bars.

**Front Panel Indicators**

All indicators are on the front panel. Figure 5 and figure 6 show HDSDI-ACR 100 and SDI-AVR 100 indicators.

- ① **Power LED** — The Power LED indicates that power is on.
- ② **720P LED (HDSDI-ACR 100 only)** — The 720P LED indicates that the converter is outputting the HDTV 720P video format.

# Indicators and Specifications

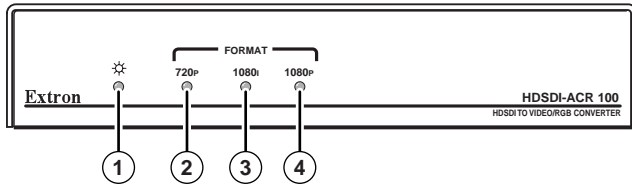

Figure 5 — HSDI-ACR 100 front panel

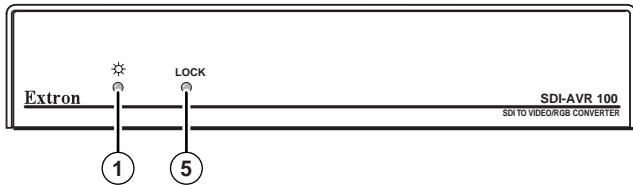

Figure 6 — SDI-AVR 100 front panel

- ③ 1080i LED (HSDI-ACR 100 only) — The 1080I LED indicates that the converter is outputting the HDTV 1080I video format.
- ④ 1080P LED (HSDI-ACR 100 only) — The 1080P LED indicates that the converter is outputting the HDTV 1080P video format.
- ⑤ Lock LED (SDI-AVR 100 only) — The Lock LED indicates that the converter is locked to the 270 Mbs input signal.

## Specifications

### Video

|                                |                   |     |
|--------------------------------|-------------------|-----|
| Differential phase error ..... | SDI-AVR 100 ..... | <1° |
| Differential gain error .....  | SDI-AVR 100 ..... | <1% |

### Video input and loop-through

|                    |   |  |
|--------------------|---|--|
| Number/signal type |   |  |
| SDI-AVR 100 .....  | 1 SDI (4:2:2, SMPTE 259M-C)               |  |
| HSDI-ACR 100 ..... | 1 HDSI (SMPTE 292M)                       |  |
| Connectors         |   |  |
| SDI-AVR 100 .....  | 1 female BNC (SDI input)                  |  |
|                    | 1 female BNC (SDI relocked loop-through)  |  |
| HSDI-ACR 100 ..... | 1 female BNC (HDSI input)                 |  |
|                    | 1 female BNC (HDSI relocked loop-through) |  |

**NOTE** The equalization applied to the SDI-AVR 100's input signal is sufficient for an input coaxial cable length of at least 1000 feet (305 meters) of Extron SHR cable or Belden 8281 cable.

The equalization applied to the HSDI-ACR 100's input signal is sufficient for an input coaxial cable length of at least 330 feet (100 meters) of Extron SHR cable or Belden 8281 cable.

|                              |                                 |
|------------------------------|---------------------------------|
| Minimum/maximum levels ..... | 0.5V to 1.0V p-p with no offset |
| Impedance .....              | 75 ohms                         |
| Return loss .....            | >-15dB @ 0 MHz to 270 MHz       |
| Maximum DC offset .....      | ±0.5V                           |

### Video processing

|                          |                                       |
|--------------------------|---------------------------------------|
| Encoder .....            | 10 bit digital                        |
| Frequency response ..... | Luminance ..... 0 to 5.75 MHz, ±0.5dB |
|                          | Chroma ..... 0 to 2.75 MHz, ±0.5dB    |
| S/N .....                | >70dB                                 |
| RGB matrix error .....   | <1%                                   |

### Video signal characteristics — for color bar output on the SDI-AVR 100 only

|                            |        |
|----------------------------|--------|
| Dot clock .....            | 27 MHz |
| Pixel clock accuracy ..... | 30 ppm |

### Video output

|                       |  |
|-----------------------|--|
| Number/signal type    |  |
| SDI-AVR 100 .....     | 1 composite video and 1 S-video, and 1 analog RGBHV/RGBS/RGsB or component video (Y, R-Y, B-Y) (switch selectable) |
| HSDI-ACR 100 .....    | 1 analog RGBHV/RGBS/RGsB or component video (Y, R-Y, B-Y) (switch selectable)                                      |
| Connectors            |  |
| SDI-AVR 100 .....     | 1 female BNC (composite video)   |
|                       | 1 female 4-pin mini DIN (S-video)  |
|                       | 6 female BNC (RGB, component video, or S-video)  |
| HSDI-ACR 100 .....    | 6 female BNC   |
| Levels .....          |  |
| Composite video ..... | 1V p-p (nominal)   |
| S-video .....         | 1V p-p/luma, 0.3V p-p/ chroma (nominal)  |
| RGB .....             | 0.7V (nominal)   |
| Component video ....  | Y = 1V p-p; R-Y, B-Y = 1V p-p (nominal)  |

**NOTE** Levels depend on the format selected (NTSC, PAL, Betacam).

